



## OVERVIEW

The ECMP3 is a remote control device used to monitor - visibly or audibly - and control the inputs and outputs of a Vector series transmitter.

In addition to a single ECMP3 monitoring and control configuration, up to four extended control/monitor panels (ECMP3's) can interface with a vector series transmitter through a VR-Link. The VR-Link allows for connections with up to three external ECMP3s and one internal ECMP3 via RS485 serial communication.

The available interconnection options allow for control/monitor capabilities at multiple locations and virtually any distance from the transmitter.

## ECMP3

### Extended Control/Monitor Panel for Vector NDB system

#### Control

Three toggle switches for extended command functions:

- RF ON/OFF
- Timer ON/OFF
- 1 user configurable spare command switch

Switches are user configurable for remote control of any command point on Vector NDB system.

#### Monitoring

Seven visual systems indicators monitor the following:

- RF ON Status
- Timer on status
- Low ac Alarm
- Changeover Alarm
- Shutdown Alarm
- VR-Link to Vector NDB communications alarm
- Vector NDB to ATU communications alarm

ECMP3 to VR-Link communications alarm can also be displayed using a combination of LED's

System indicators can be configured by the user if standard configuration does not meet the site specific requirements.

An audible alarm is provided and is user configurable to activate from any of the status alarm inputs as either asserted or having changed state.

An acknowledge button is provided to silence the recurrence of an audible alarm.

A test button is provided to allow the user to verify that all visual indicators and audible alarms are operational.

The ECMP3 is equipped with three levels of brightness and volume control

#### Interface

ECMP3 connected to NDB via direct parallel wire connection

The optional site control/monitor PWB, used to provide additional control and monitor points external to the Vector NDB, is required to interface the ECMP3 to the Vector NDB

#### Range

ECMP3 provides extended control/monitor functions for the Vector NDB system at a maximum distance of 152 m (500 ft) when connected directly.

#### Environmental

Temperature Range  
-30 °C to +50 °C (operating)  
-40 °C to +80 °C (storage)

#### Humidity

0 to 95% relative humidity (non-condensing)

#### Supply Voltage

9 V to 15 V dc  
(note: the ECMP3 ancillary kit contains an ac to dc power supply that can be used as the electrical power supply. This power supply accepts a voltage between 100 V and 240 V ac, 50/60 Hz)

#### Dimensions

Rack Mounted

48.2 cm W x 13.3 cm H x 16.2 cm D  
(19" W x 5.25" H x 6.38" D)

Console Mounted

7.1 cm W x 12.9 cm H x 16.2 cm D  
(2.79" W x 5.06" H x 6.38" D)

(Use of the ECMP3 requires the purchase and installation of the optional site control/monitor pwb in the Vector NDB system when connected directly)

## VR-LINK / ECMP3 INTEGRATION

### VR-Link with Integrated ECMP3

ECMP3 can be integrated with VR-Link using standard VR-Link connections to provide the combined monitoring and control capabilities of both devices for one NDB and ATU. Using ECMP3 in conjunction with VR-Link allows control and monitoring functions of ECMP3 to be utilized remotely.

### Connecting multiple ECMP3 units via VR-Link

Up to four (one internal to VR-Link) ECMP3 units can be connected to one VR-Link simultaneously for control of the NDB. The ECMP3 is connected to the VR-Link with standard serial (RS485) connections. ECMP3 units can be located up to 1 km from VR-Link.

# ECMP3



## Vector NDB & ECMP3 Interconnection

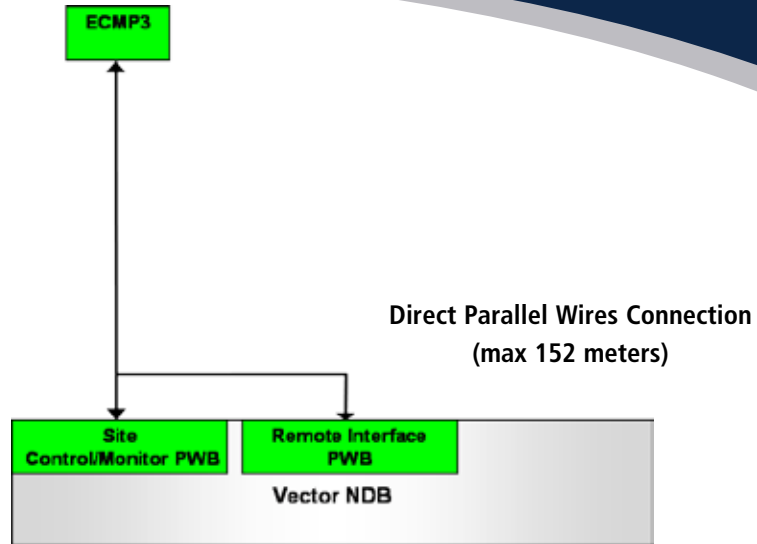

## Vector NDB & VR-Link Interconnection Options (VR-Link Installed at Remote Location)

\* Up to 3 ECMP's can be connected to the VR-Link simultaneously

